



TECHNICAL GUIDANCE

PERFECT ISOLATION BY MAGNET COUPLING
COVERING HIGH TEMP., HIGH PRESS., AND VACUUM APPLICATIONS
PRESSURE TIGHT FLAMEPROOF FOR HYDROGEN ATMOSPHERE READY
SPRING BALANCED DISPLACER TYPE

FS-100 Series LEVEL SWITCH

OUTLINE

FS-100 is a spring balanced displacer type level switch.

The pressurized part and electric part are perfectly isolated by magnet coupling system to offer much more safety and durability compared to other mechanical sealing types.

FS-100 can meet tough application with high temperature and high pressure.

Hermetical seal switch is newly added for heavy duty applications.



HERMETIC SEALED
SWITCH AVAILABLE

FEATURES

- Wide selection range for temperature and pressure.
- Variety of material selection for displacer, spring and chambers for suitable anticorrosive capability.
- Perfect isolation between pressurized part and electric compartment by magnetic coupling for high reliability and safety.
- In addition to watertight construction, pressure tight and intrinsically safe versions are ready to meet hazardous application.
Especially, pressure tight flameproof suitable for Hydrogen atmosphere (Ex dIIC T6) is available which eliminates the necessity of safety barriers.

MAIN APPLICATIONS

- Fuel oil tank level control
- Process control for petrochemical plants
- Nuclear, thermal, and Hydric power station process control
- Water treatment plants
- Oil rig's platform
- Other liquid level control

STANDARD SPECIFICATION

- Detection theory : By spring balanced displacer
- Measuring object : All types of liquids
(Liquid level or liquid interface)
- Density : For level detection 0.45 g/cm³ or more
For liquid interface detection*
Difference of 0.2 g/cm³ or more
*Number of points for alarm: 1 point
- Viscosity : Max. 600 mPa*s. Liquid without sticking, crystallization, or freezing
- Accuracy : ±10mm (Density 1.0g/cm³)
(For level detection with water (AMB, ATM))
- Repeatability : ±5mm (Density 1.0g/cm³)
(For level detection with water (AMB, ATM))
- Reset span : Max.40mm (Density 1.0g/cm³)
(For level detection with water (AMB, ATM), 1 point for alarm)
- Pressure range : Full vacuum to 4.9MPa
- Temp. Range : -60 to 400°C
(Upto -196°C on request. Consult factory for details.)
- Enclosure :

Watertight	IP65 Equ.	FS-10 □ W
Pressure tight flameproof	Ex d IIC T6	FS-10 □ EX
Intrinsically safe	EX ia IIC T6	FS-10 □ S
- Amb. Temp. : -20 to +80°C
-20 to +55°C for pressure tight flameproof
-20 to +60°C for Intrinsically safe versions
- Type of process connection and flange sizes :
 - ◎ : Standard
 - : Optionally available
 - : Not available

- Standard Material:
(Refer to MODEL CODE for special material availability)
- Liquid wetting part

Displacer	SUS304, SUS316, SUS316L
Spring	SUS316
Rod	SUS316
Wire	SUS316
Chamber	Carbon steel, SUS304, SUS316, SUS316L
- Vapor contacting part

Lead pipe	SUS304, SUS316
Top flange	Carbon steel, SUS304, SUS316 SUS316L
- Non-contacting part

Electric housing	Aluminum die-casting
------------------	----------------------
- Alarm contact : 1,2,3 or 4 points
Limitation based on switch type and temperature range are applicable, Refer to MODEL CODE① for further details.
- Type of contact : Standard SPDT Microswitch
Options 2SPDT
(Equ. to DPDT action)
Hermetical sealed
Microswitch
- Contact capacity : Refer to Model CODE ①
- Cable entry:

Model	Classification	Cable entry	Remarks
FS-10 □ W	Watertight	G3/4	—
FS-10 □ EX	Ex d IIC T6	G1/2	Cable dia. ø9 to 11
		G3/4	Cable dia. ø12 to 14
FS-10 □ S	Ex ia IIC T6	G3/4	—

NPT thread etc. are applicable with adapter.

- Terminal : FS-10 □ W, EX, S
: Up to 150°C - M3.5 screw
Over 150°C - M3 screw
- Painting : For liquid temp. upto 150°C
Polyurethan resin painting
For liquid temp. more than 151°C
Silicone resin painting
- Colour : Silver (standard)

The HPGCL-certified version is available. Contact us for details.

① Tank top, welding Internal chamber type

Size	Density<0.68g/cm ³	Density≥0.68g/cm ³
80mm (3")	—	◎
100mm (4")	◎	○
125mm (5")	○	○
150mm (6")	○	○

② Tank top, insertion internal chamber type

Size	Density<0.68g/cm ³	Density≥0.68g/cm ³
80mm (3")	—	—
100mm (4")	—	◎
125mm (5")	◎	○
150mm (6")	○	○

③ Tank side, external chamber type

Size	Density<0.68g/cm ³	Density≥0.68g/cm ³
80mm (3")	—	◎
100mm (4")	◎	○
125mm (5")	○	○
150mm (6")	○	○

INSTRUCTION FOR USE

- The FS level switch with a spring operates in response to changes in the buoyancy of the displacer. Because alarms are set at a given operating density and temperature, if the density or temperature changes, the alarm level may shift or the alarm may not be issued.
- Do not use this switch in tanks with a mixer or other similar apparatus.

ALARM POINT

The following limitation on alarm setting point is applicable due to technical reasons.

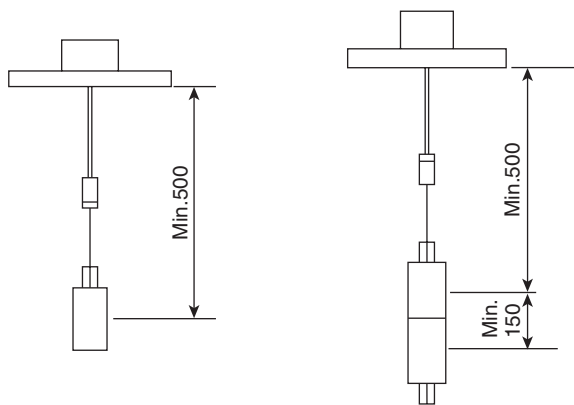

● For 1 point alarm
(H or L)

● For 2 points alarm
(H-H, H-L or L-L)

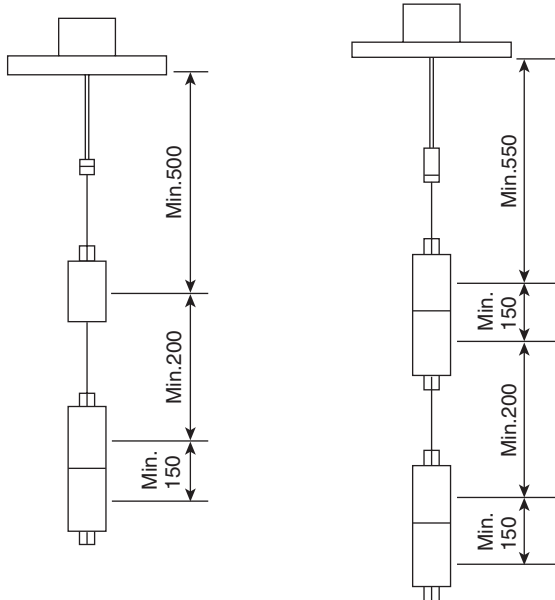

● For 3 points alarm
(H-H-L or H-L-L)

● For 4 points alarm
(H-H-L-L)

INTRINSICALLY SAFE RELAY (EB3C)

Intrinsically safe relay is to be inserted into the contact loop of FS-10□S type level switch. 1 to 3 points use relays are available. Select suitable IS relay considering the total number of contacts.

Standard specification

Explosion protection	Intrinsically safe Ex ia IIC
Rated operating voltage	DC12V±10%
Rated operating current	DC10mA±20%
Installation location	Non-hazardous area
Contact configuration	1a contact
Relay output	AC250V, 3A
(Resistance load)	DC24V, 3A
Contact allowable power	AC750VA
(Resistance load)	DC72W
Insulation resistance	DC500V at 10MΩ
Withstand voltage	AC1500V (1 min.)

Model code			Description
EB3C-	R	□□ □	Model
Output type	R		Relay output
No. of contact		01	1 point use
		02	2 points use
		03	3 points use
Power supply	A		AC100V to 240V, 50/60Hz
	D		DC24V

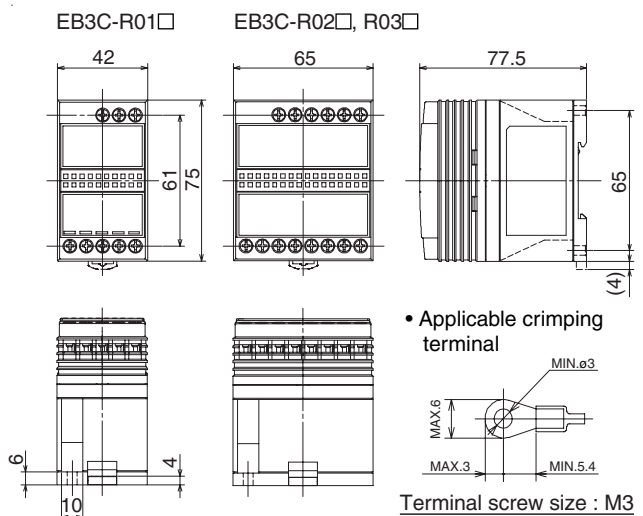

EB3C Dimensions

CAUTIONS FOR PIPING

- In case of the frameproof type (FS-10□EX) and intrinsically safe type (FS-10□S) to be used in Japan, the cable wiring is to be conducted in accordance with the enforcement regulations of "Cable Wiring" system in FLAMEPROOF TYPE CABLE WIRING as specified in "Industrial Safety and Health Law". For details, refer to "USER'S GUIDELINES for Electrical Installation for Explosive Gas Atmospheres in General Industry" edited by MINISTRY OF HEALTH, LABOUR AND WELFARE RESEARCH INSTITUTE OF INDUSTRIAL SAFETY JAPAN.
- FS-10□EX type pressure tight flameproof version is certified for Ex d II C T 6 classification under the condition of using our designated pressure tight cable glands which are delivered together with level switches. They are to be properly installed.

MODEL CODE

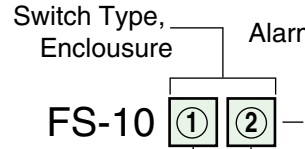

① SWITCH TYPE, TEMP, CLASS

CODE	LIQUID TEMP (°C)	ON/OFF MECHANISM TYPE	CONTACT TYPE	SWITCH MODEL	SWITCH SUPPLIER	CONTACT CAPACITY	NO. OF COOLING FIN	MAX POSSIBLE ALARM CONTACT	
1	-25~150	GENERAL PURPOSE	SPDT	VX-5-1A2	OMRON	AC250V, 5A DC125V, 0.4A	0	4	
2	151~230			V5-1A3T		1	4		
3	231~280			EARTHQUAKE PROOF (3G) TYPE		TZ-1GV	AC250V, 1A DC125V, 0.4A	1	1
4	281~400						2	1	
5	-25~150	GENERAL PURPOSE	2SPDT	VX-5-1A2	Yamatake	AC250V, 5A DC125V, 0.4A	0	2	
6	151~230			V5-1A3T		1	2		
7	231~280	EARTHQUAKE PROOF (3G) TYPE	TZ-1GV	AC250V, 1A DC125V, 0.4A		1	1		
8	281~400			2		1			
A	-25~150	HERMETIC SEAL TYPE	SPDT	11SM244	Yamatake	AC250V, 5A DC125V, 0.3A DC30V5A	0	2	
B	151~280					1	1*1		
C	281~350					2	1		
D	-25~150					SPDT (GOLD PLATED)	SSM13A0	AC125V, 0.1A DC30V, 0.1A	0
E	151~200		1	2					
F	-25~150		2SPDT	11SM244	Yamatake	AC250V, 5A DC125V, 0.3A DC30V, 5A	0	2	
G	151~280					1	1*1		
H	281~350					2	1		
I	-25~150					2SPDT (GOLD PLATED)	SSM13A0	AC125V, 0.1A DC30V, 0.1A	0
J	151~200		1	2					
K	-25~150		EARTHQUAKE PROOF (3G) TYPE	SPDT	VX-5-1A2	OMRON	AC250V, 5A DC125V, 0.4A	0	2
L	151~230				V5-1A3T			1	2
M	-25~150	2SPDT		VX-5-1A2	0			2	
N	151~230			V5-1A3T	1			2	
Z	-	SPECIAL	-	-	-	-	-	-	

*: For applications with lower temperature than -26°C, an extension unit will be added and the external dimension will be different from the standard versions. Consult factory for details.
 *: Applicable alarm of interface detection is 1 point.
 *1: 230°C or less are 2 points.

④ PRESSURE RATING

CODE	PRESSURE RATING
1	10K(150#) Class
2	20K(300#) Class
3	30K(600#) Class
4	HIGH PRESS. APPLICATION
Z	OTHERS

⑤ TOP FLANGE MATERIAL

CODE	TOP FLANGE MATERIAL
S	CARBON STEEL
4	SUS304
6	SUS316
L	SUS316L
Z	OTHERS*

* Available special material
 TP35 (Titanium), Monel, MA276 (Equ. to HASTELLOY C)

② ENCLOSURE

CODE	ENCLOSURE
W	WATERTIGHT (IP65EQU.)
EX	PRESSURE TIGHT EX-PROOF (Ex d IIC T6)
S	INTRINSICALLY SAFE EX-PROOF (Ex ia IIC T6)

③ NUMBERS OF ALARM

CODE	NUMBER OF ALARM
1	1 POINT
2	2 POINTS
3	3 POINTS
4	4 POINTS

Refer to MODEL CODE ①.

⑥ LEAD PIPE MATERIAL

CODE	LEAD PIPE MATERIAL
4	SUS304
6	SUS316
Z	OTHERS*

* Available special material
 SUS316L, MA276 (Equ. to HASTELLOY C)

⑦ DISPLACER MATERIAL

CODE	DISPLACER MATERIAL
6	SUS316 (Standard)
4	SUS304
L	SUS316L
Z	OTHERS*

* Available special material
 TP35 (Titanium), Monel, MA276 (Equ. to HASTELLOY C) [ETFE, PFA]
 The material in a parenthesis has temperature restrictions.
 Consult factory for details.

⑧ SPRING MATERIAL

CODE	SPRING MATERIAL
6	SUS316
Z	OTHERS*

* Available special material
 MA276 (Equ. to HASTELLOY C), INCONEL
 (INCONEL is selected for applications more than 231°C temperature.)

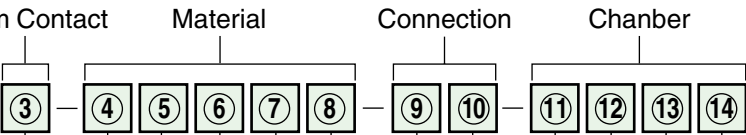

⑭ UPPER GASKET MATERIAL

CODE	UPPER GASKET MATERIAL
0	CUSTOMER'S SCOPE (CHAMBER NOT PROVIDED)
T	PTFE covered (For 10K rating only)
4	VORTEX GASKET (SUS304)
6	VORTEX GASKET (SUS316)
Z	OTHERS*

* Bolts, nuts and gaskets for process connection are to be supplied by the customer.

⑬ EXTERNAL CHAMBER CONNECTION

CODE	EXTERNAL CHAMBER CONNECTION
0	CHAMBER NOT PROVIDED
1	1"SW
2	Rc1
3	1"FLANGE*
Z	OTHERS

⑫ CAMBER MATERIAL

CODE	CHAMBER MATERIAL
0	CHAMBER NOT PROVIDED
S	Carbon steel
4	SUS304
6	SUS316
L	SUS316L
Z	OTHERS*

* Available special material
SUS304L, SUS316L TP35(Titanium), Monel,
MA276 (Equ. to HASTELLOY C)

⑪ CHAMBER CONTRUTION

CODE	CHAMBER CONTRUTION
0	NOT PROVIDED
1	INTERNAL, WELDING TYPE(FIG.A)
2	INTERNAL, INSERSION TYPE(FIG.B)
3	EXTERNAL, SIDE-SIDE (FIG.C)
4	EXTERNAL, SIDE-BOTTOM (FIG.D)
Z	OTHERS

⑨ TOP FLANGE SIZE

CODE	TOP FLANGE SIZE
3	80mm(3")
4	100mm(4")
5	125mm(5")
6	150mm(6")
Z	OTHERS

⑩ TOP FLANGE SIZE RATING

CODE	TOP FLANGE SIZE RATING
0	JIS10KFF
1	JIS10KRF
2	JPI#150
3	ANSI#150
4	JIS20KRF
5	JPI#300
6	ANSI#300
Z	OTHERS

DIMENSIONS

1. DETECTING PART

FS-10 ^{1W}/_{5S}

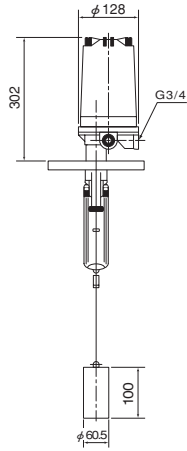

FS-10 ^{2W}/_{3S}

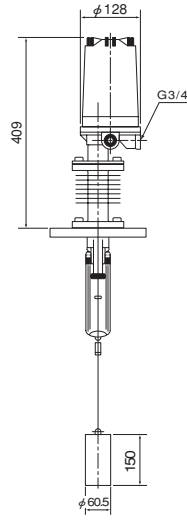

FS-104W

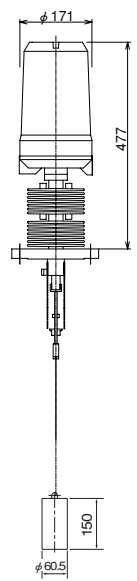

FS-10₅¹EX

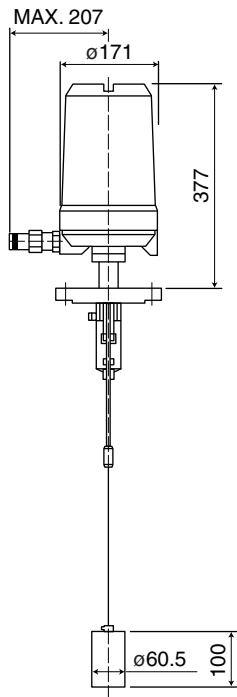

FS-10₃²EX

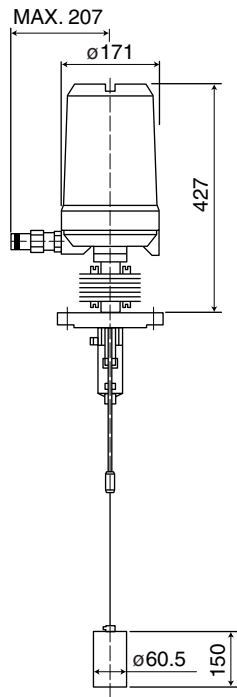

FS-104XE

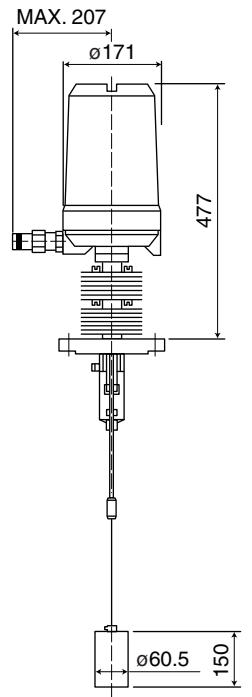

2. CHAMBERS

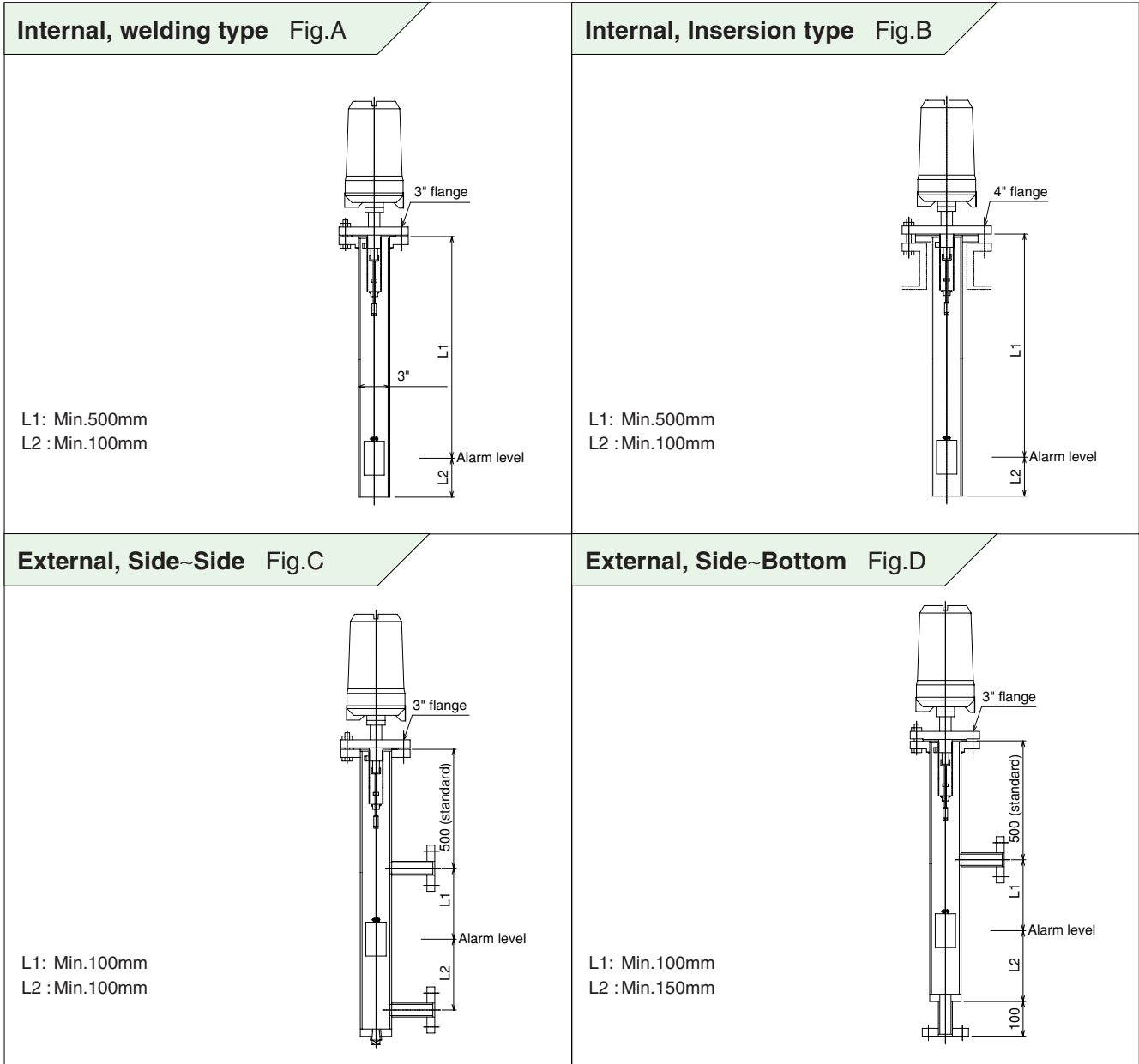

3. DISPLACER

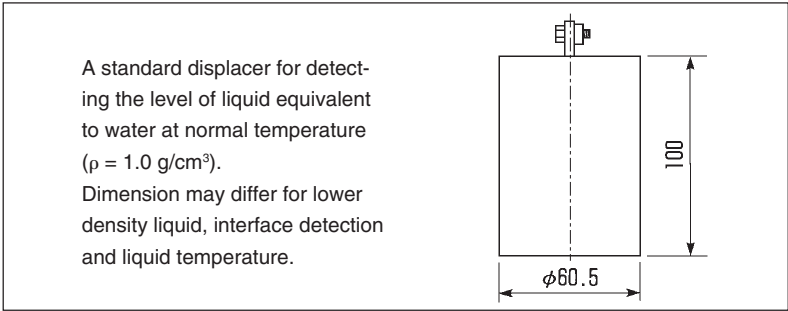

ORDERING INFORMATION

Please notify the follow for order / inquiry :

TAG NO.				
MODEL	FS-10□□-□-□□□□□□-□□-□□□□			
Q'TY				
LIQUID NAME	For liquid level detection			
	For two liquids interface detection		Upper	Lower
DENSITY	For liquid level detection			
	For two liquids interface detection		Upper	Lower (Difference of at least 0.2 g/cm ³ required. Only 1 point for alarm.)
PRESS.	Nor.	Max.	<input type="checkbox"/> MPa	<input type="checkbox"/> ()
TEMP	Nor.	Max.	<input type="checkbox"/> °C	<input type="checkbox"/> ()
ALARM POINT, SETTING, INSTRUCTION	<input type="checkbox"/> 1 point alarm	<input type="checkbox"/> 2 points alarm	<input type="checkbox"/> 3 points alarm	<input type="checkbox"/> 4 points alarm
	<p>h1 ___ mm <input type="checkbox"/> High <input type="checkbox"/> Low</p>	<p>h1 ___ mm <input type="checkbox"/> High <input type="checkbox"/> Low h2 ___ mm <input type="checkbox"/> High <input type="checkbox"/> Low</p>	<p>h1 ___ mm High h2 ___ mm <input type="checkbox"/> High <input type="checkbox"/> Low h3 ___ mm Low</p>	<p>h1 ___ mm High h2 ___ mm High h3 ___ mm Low h4 ___ mm Low</p>
Limitation of alarm setting point is applicable due to technical reason. Refer to Page 3 for details.				
CHAMBER	<input type="checkbox"/> Not required	<input type="checkbox"/> Internal welding type	<input type="checkbox"/> Internal insertion type	<input type="checkbox"/> External, Side~Side
	<input type="checkbox"/> External, Side~Bottom			
l : <input type="checkbox"/> ___ mm		l : <input type="checkbox"/> ___ mm		l ₁ : <input type="checkbox"/> Standard (500mm) <input type="checkbox"/> ___ mm l ₂ : <input type="checkbox"/> ___ mm l ₃ : <input type="checkbox"/> ___ mm
APPLICATION	<input type="checkbox"/> General		<input type="checkbox"/> Nuclear	<input type="checkbox"/> High Pressure Gas Application
OTHER SPECIAL FEATURES AND INSTRUCTION	<hr/> <hr/> <hr/>			

* Specification is subject to change without notice.

TIV TOKYO KEISO CO., LTD.

Head Office : Shiba Toho Building, 1-7-24 Shibakoen, Minato-ku, Tokyo 105-8558
 Tel : +81-3-3431-1625 (KEY) ; Fax : +81-3-3433-4922
 e-mail : overseas.sales@tokyokeiso.co.jp ; URL : http://www.tokyokeiso.co.jp

