



FAST & FLUID MANAGEMENT

**SK350**

ENGLISH

# Table of Contents

<b>SK350 Manual</b>	
Introduction, warranty & CE certification	Pag. 3
Main SK350 components	Pag. 4
Safety instructions	Pag. 5
Installation	Pag. 6 – 8
Operation	Pag. 9 – 12
Maintenance	Pag. 13
Problem solving	Pag. 14 – 15
Service and Support, Fuses	Pag. 15
Specifications	Pag. 16
Electrical wiring diagram	Pag. 17
Contributing to the Protection of the Environment	Pag. 18

# Introduction & warranty

## Introduction

By selecting a Fast & Fluid Management shaker you have opted for a product which is the result of intensive research. Top-quality components, craftsmanship and a modern ergonomic design all serve to guarantee a long service life and a high degree of user friendliness.

## Warranty

In these warranty conditions, 'F&FM' is understood to mean Fast & Fluid Management. The warranty conditions incorporated into F&FM's general conditions of sale are summarized as follows (for free general conditions you can contact F&FM).

F&FM guarantees the proper operation of any goods which it supplies, for a period of one year, except where a breakdown is the result of normal wear and tear. The cost of any inspection activities carried out by F&FM, with the aim of establishing whether or not a breakdown is covered by the warranty will be reimbursed by the other party if it transpires that the breakdown is not covered by the warranty. If it transpires that a breakdown is covered by the warranty then F&FM will supply identical or equivalent goods under the conditions referred to in point 6 of the general conditions of sale. The warranty obligation described in this article only applies if the goods supplied by F&FM have been used in accordance with the manual. Time spent on warranty-related activities, including travel time, travel costs and accommodation costs, are charged at current rates.

In contrast to the above, F&FM will not be held to any warranty obligation if:

1. Repairs have been carried out, or attempted, by the other party or a third party, unless F&FM had previously declined to repair the goods for a fair price;
2. F&FM demonstrates that the defect did not emerge during testing;
3. The other party fails to inform F&FM of the defect immediately, if possible either by letter and/or by fax, providing full, accurate details and/or has failed to comply fully with F&FM's instructions;
4. The other party has failed to use or treat the goods properly or in accordance with F&FM's instructions;
5. The damage has been caused by incidents, beyond F&FM's supervision, which have occurred either during transport or installation.

## CE certification

The machine is CE certified. It means that the machine complies with the essential requirements concerning safety and hygiene. The directives that have been taken into consideration in the design are available on [www.fast-fluid.com](http://www.fast-fluid.com).

## Main SK350 components

1. Top lid
2. Keyboard & Emergency stop button
3. Transformer
4. Power Board
5. Removable front panel
6. Clamping plate
7. Super strut – suspension
8. Door handle
9. Shaker frame
10. Can table
11. Can mounting rim
12. Excenter axle
13. Shaker motor & driving belt

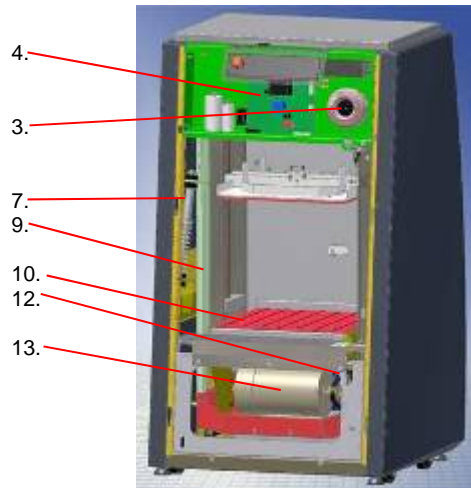
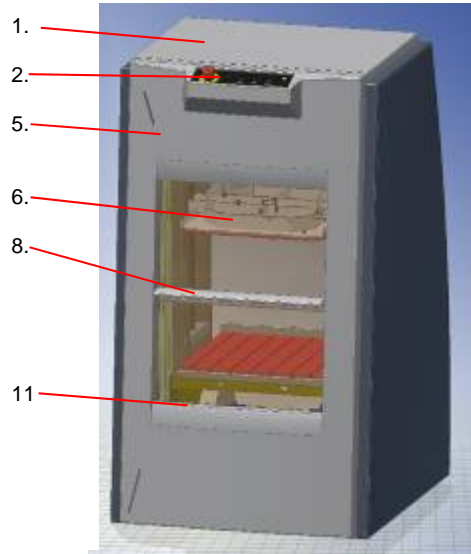

# Safety instructions

## General safety instructions



**Attention! Before installing the equipment and setting it in operation, please read the instructions carefully. This is safer both for yourself and prevents unnecessary damage to the machine.**

The manufacturer accepts no liability if the instructions below are not followed:

1. If a machine has been damaged (during transport, for example), do not attempt to set it in operation. When in doubt, first contact either your supplier or the F&FM service department.
2. The equipment should be positioned and connected up in strict accordance with the installation instructions.
3. All local safety regulations and ordinances should be observed.
4. The machine may be connected only to a 220-240V/16A/50Hz earthed wall socket installed in accordance with the regulations.
5. Users should see to it that the machine is kept in good condition. Defective components should be replaced.
6. In order to prevent physical injury, the doors should be closed and the paneling fitted during normal use.
7. All service activities (other than routine maintenance and adjustments) may only be carried out by qualified technicians. See to it that the mains lead is always kept unplugged while repairs are being carried out.

## Specific safety instructions in this manual



**Attention! Failure to remove the frame lock correctly can result in severe damage to your SK350 when in operation. Please take care!**



**Attention! To prevent damage, the SK350 may only be connected to either 220-240V/16A/50Hz power grids.**



**Attention! Only use the emergency stop button in case of a true emergency. After pressing the emergency stop, wait at least 15 seconds before unlocking it (turn clockwise). The SK350 will then reset and unclamp the container.**



**Attention! MOVING PARTS CAN CAUSE INJURY. Always turn off power (e.g. by pressing emergency stop) before accessing moving parts.**

## Installation

### Step 1 - Unpack the machine and unlock the frame lock



Remove box and plastic foil. Note the frame lock bolts on either side of the machine.

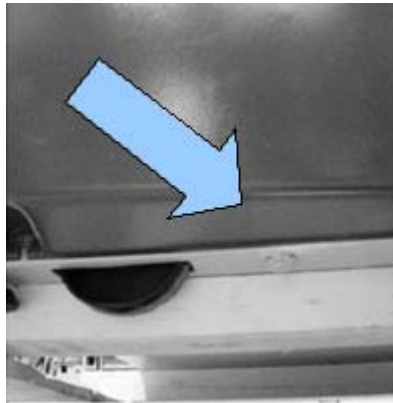

Remove both bolts with a size 17 fork wrench.



By removing the bolts, the frame lock's wooden block is released.



**Be careful not to damage the body and surfaces of your SK350 with any tools while unpacking it. Take care not to accidentally close the door before finishing installation, as it can then only be unlocked power on the machine.**

### Step 2 - Remove the frame lock



Pull out cord to remove frame lock's loose parts.

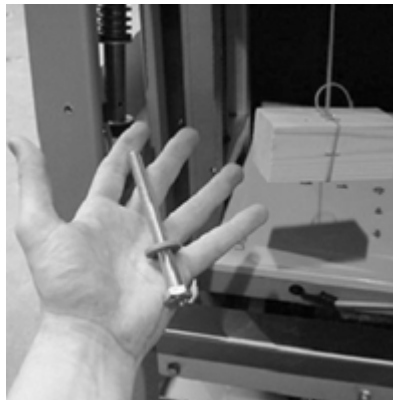

Ensure all loose parts have been removed – two bolts and two wooden blocks.



Connect the SK350 to the power mains before closing the door.



**Attention! Failure to remove the frame lock correctly can result in severe damage to your SK350 when in operation. Please take care!**



**Please take care to store the frame lock for later use, it is essential for correct transportation.**

### Step 3 - Detach shaker from its transport skid

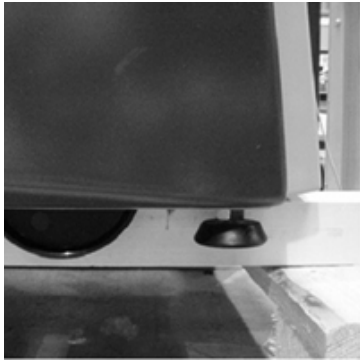

Push the machine from the pallet onto the ground



Push the machine to the final location



**For optimal mixing results and silent operation it is essential to correctly level the machine and lock the adjustable feet.**

### Step 4 - Place the machine in its final operational position



Lower the adjustable feet far enough to lift the machine off its wheels.



Take care to correctly level the machine (by turning the adjustable feet).



Lock all adjustable feet by tightening the their separate bolts.



**Tip: before locking the adjustable feet, start a mixing cycle with a small load (<5kg). While the SK350 runs, check if all four feet are firmly in contact with the floor and then lock them.**

## Step 5 - Electrical connection



V

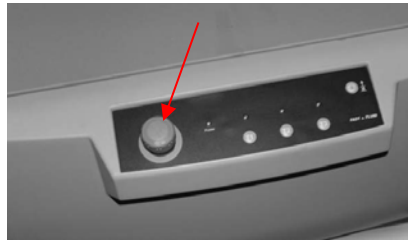

Connect the power cable to the socket at the rear of the machine.

Ensure the emergency stop is unlocked (turn clockwise).



**Attention! To prevent damage, the SK350 may only be connected to either 220-240V/16A/50Hz power grids.**



## Operation

### A - First time operation



**Attention! Before operating your SK350 for the first time, please ensure the frame lock was correctly removed (as indicated in pag.6)**

### Step 1 – SK350 power management



Turn the emergency stop clockwise to unlock: the power led is lighted-ON.

Unlock the emergency stop button on the front of the machine by turning clockwise. The machine is automatically switched on when the power connector at the rear of the shaker is plugged into a 220-240V wall socket. The power led lighted-ON.

The machine is in stand-by modus. To awake the machine from its sleeping modus, press any of the interface buttons.

Please note that during normal operation there should be no reason ever to take the power off the machine. In case the shaker must be switched off (e.g. for maintenance) there is only one way of achieving this: unplug the power connector at the back of the machine.



**Attention! To prevent damage, the SK350 may only be connected to either 220-240V/16A/50Hz power grids.**

## Step 2 - Correct placement of cans and other containers

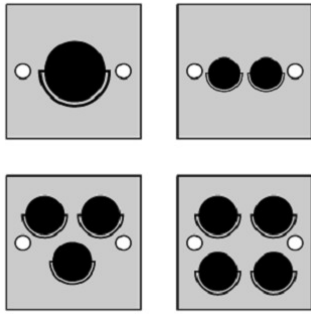

Place one or more containers at gravitational center of the can table, between the spindles.



Place filler disc on lid to prevent displacement during operation.



Remove the can handle before shaking. When mixing more than one can, use adhesive tape.

## Step 3 – SK350 Control interface

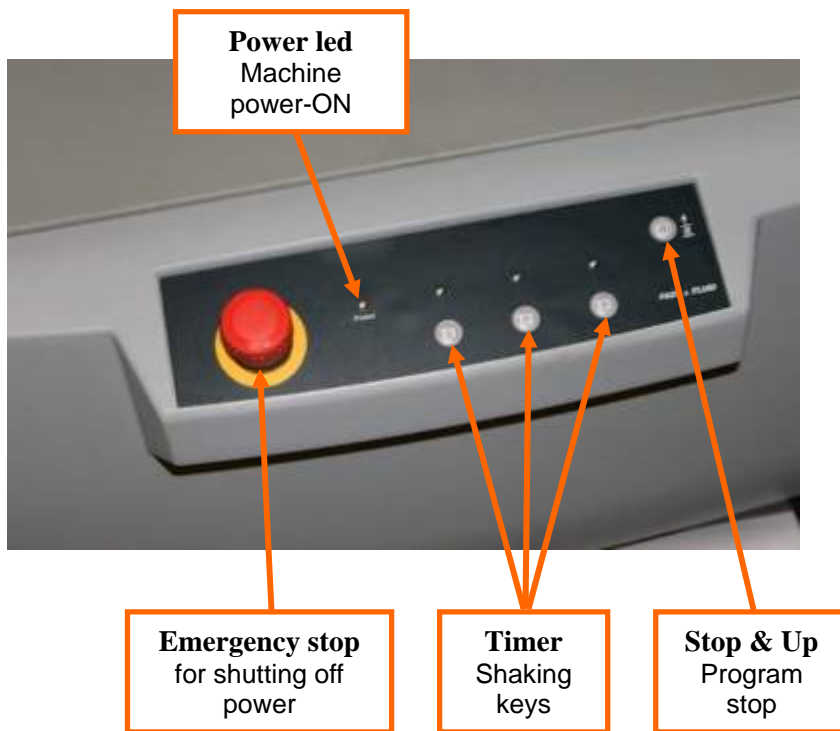

## B - Operating the SK350

Step 1 - Place can, choose the shaking time and push the start key



>



>

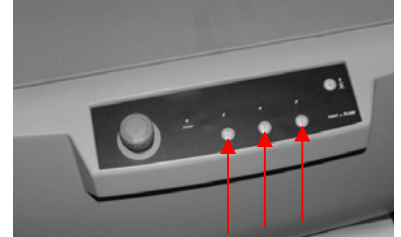

Place the container in the can table center, place filler disc

Close door.

Choose shaking time T1, T2 or T3 and press desired timing button. Clamping and mixing will now start.



**Attention! The mixing program will not start unless the door is closed.**

Step 2 - Program ends or is interrupted, remove can



>



>



To interrupt the mixing program, press the stop button. Use the emergency stop only in case of a true emergency.

When the program finishes or is interrupted with the stop button, the SK350 will unclamp automatically.

Open door and remove container.

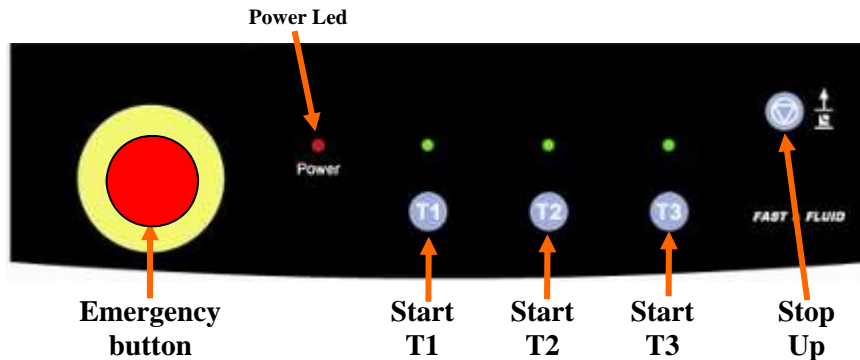

**Attention! Only use the emergency stop button in case of a true emergency. After pressing the emergency stop, wait at least 15 seconds before unlocking it (turn clockwise). then press Stop/up Key to unclamp the container.**

C - User of the SK350**Keyboard**

Check if the machine has been correctly installed and power on

Turn the emergency stop clockwise to unlock

Open the door and container(s) inside as described in the chapter "operation" step 2.

Close the door.

Push on start key(s) to start the machine. Follow the default shaker times.

T1	T2	T3
30sec.	60sec.	150sec.

It is possible to push (in the same time) 2 or 3 keys to add the stirring times as indicated:

T1+T2	T1+T3	T2+T3	T1+T2+T3
1min. and 30sec.	3min.	3min and 30sec.	4min.

The clamping plate will move downwards and will clamp the container, immediately the shaking starts for the setting time

After the shaking period the machine shall stop and will move the clamping plate automatically upwards. Before opening the door and remove the container please wait till the frame is not moving anymore. If necessary place a new container, close the door and repeat procedure.

**Notes:**

The shaking cycle can be interrupted while it is in progress by pressing the Stop/Up-button. The clamping plate will automatically move upwards then.

In an emergency, pressing the emergency switch can also interrupt the shaking cycle. In this case it is released by turning it a quarter turn to the left.

**WARNING:** Do not reach into the machine until it has come to a complete standstill!

## Maintenance

Keep your SK350 clean and free of paint residue



>

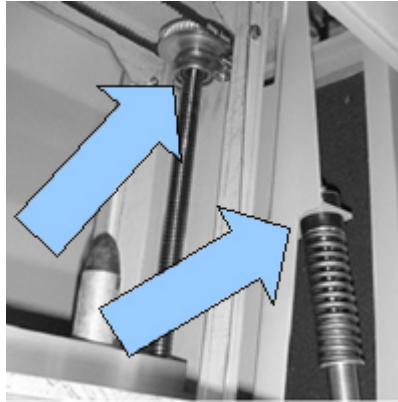

Remove all spilt paint from accessible parts (especially clamping plate spindles). Use diluted detergent only and Teflon spray only.

Though the SK350 is designed to be completely maintenance free, periodic greasing of moving parts will ensure it remains in top shape.



**Attention! MOVING PARTS CAN CAUSE INJURY. Always turn off power (e.g. by pressing emergency stop) before accessing moving parts.**

# Problem solving

## Introduction

Before calling your machine supplier or Service Department, please check whether you can solve the problem yourself. If you cannot, then call the Service Department for advice. Have the model number and serial number at hand (these can be found on the silver sticker at the back of the machine). Use the Problem Solving chart below to judge whether you can solve a problem yourself or whether you need to call in the Service Department. On no occasion remove side panels yourself, this may only be done by trained service personnel.



**Attention! MOVING PARTS CAN CAUSE INJURY. Always turn off power (e.g. by pressing emergency stop) before accessing moving parts.**

## Problem Solving

<i><b>Symptom</b></i>	<i><b>Cause</b></i>	<i><b>Action</b></i>
Main power supply is present but the machine does not work	Door of the machine is open	Close the door
	Emergency stop is active	Turn emergency stop clockwise
	Machine is overloaded	Unload (max 35 kg)
	Fuse blown (on the socket)	Shut power off and replace fuse (see page 15)
	Door switch is defective	Call service
	Keyboard is defective	Call service
	Fuse F3= 1A blown (on the main board)	Call service
Extreme vibration when mixing	Main board is defective	Call service
	Machine incorrectly loaded	Place load in can table center
	Machine is not level	Level the machine
	Adjustable feet set incorrectly	Adjust all feet so they support the machine properly and lock them into position.
Clamping plate goes down, then nothing happens	Suspension struts are defective	Call service
	Fuse F2 = T8A blown (on the main board)	Call service
	Main board is defective	Call service
	Shaker motor is defective	Call service
Clamping plate will not go down	Start relais or capacitors are defective	Call service
	Clamping plate jammed	Call service
	Clamping motor is defective	Call service
	Cable of the clamping motor is defective	Call service
	Main board is defective	Call service
	Door switch defective	Call service

Machine starts shaking before the container has been clamped	Too much spindle resistance	Clean the spindles and lubricate
	Clamping plate force incorrectly set	Call service
Clamping plate will not go up after mixing	Clamping plate is jammed	call service
	Clamping motor is defective	Call service
	Cable of the clamping motor is defective	Call service
	Main board is defective	Call service
Container unclamps while mixing	Container(s) not centered	Replace container(s) in gravitational centre.

## Service and Support

If necessary, you can get in touch with your supplier or the local service department, or contact the manufacturer directly. If you contact the manufacturer, make sure that you have the model number and serial number to hand. They can be found on the nameplate on the machine.

For more information please visit our website [www.fast-fluid.com](http://www.fast-fluid.com)

## Fuses

### Replace fuse at rear of SK350.



Remove mains connector and pull fuse tray outwards.

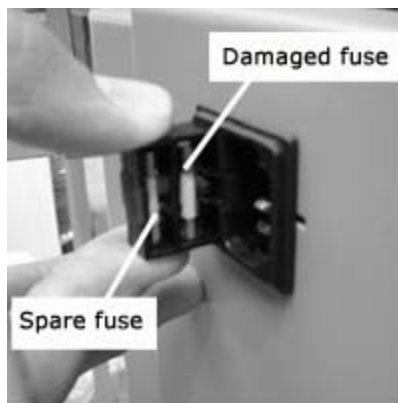

The inner fuse is the (damaged) one to replace, the outer is the spare to replace it with.

Dispose of the burnt fuse and in time, remember to get a new spare, type 5x20/T10A (slow). If problem persists, check mains for power surges.

## Specifications

Maximum product weight	35 kg
Timer	Default shaking time: T1=30sec; T2=60sec.; T3=150sec OR T1+T2=1min.&30sec; T1+T3=3min.; T2+T3=3min.&30sec.; T1+T2+T3=4min.
Maximum product size (H x W x D)	45 x 35 x 35 cm
Minimum product height	7 cm
Clamping	Automatic
Clamping pressure	Adjustable (default value <b>300Kg</b> )
Product access	Internal sliding door
Shaking speed	700 rpm
Large can table	standard
Machine size (H x W x D)	116 x 72 x 61 cm
Machine weight (empty)	180 kg
Power input	750W
Power supply	220-240V/16A/50Hz
Environmental conditions are within these limits	Ambient air temperature: from +5C° to 40°C  Relative humidity: up to 50% when the T° max is 40°C. The relative humidity can reaches 90% if the T° max is 20°C  Altitude: The electrical equipments work correctly up to 1000m above mean sea level
Specifications subject to change without prior notice.	



# Electrical wiring diagram

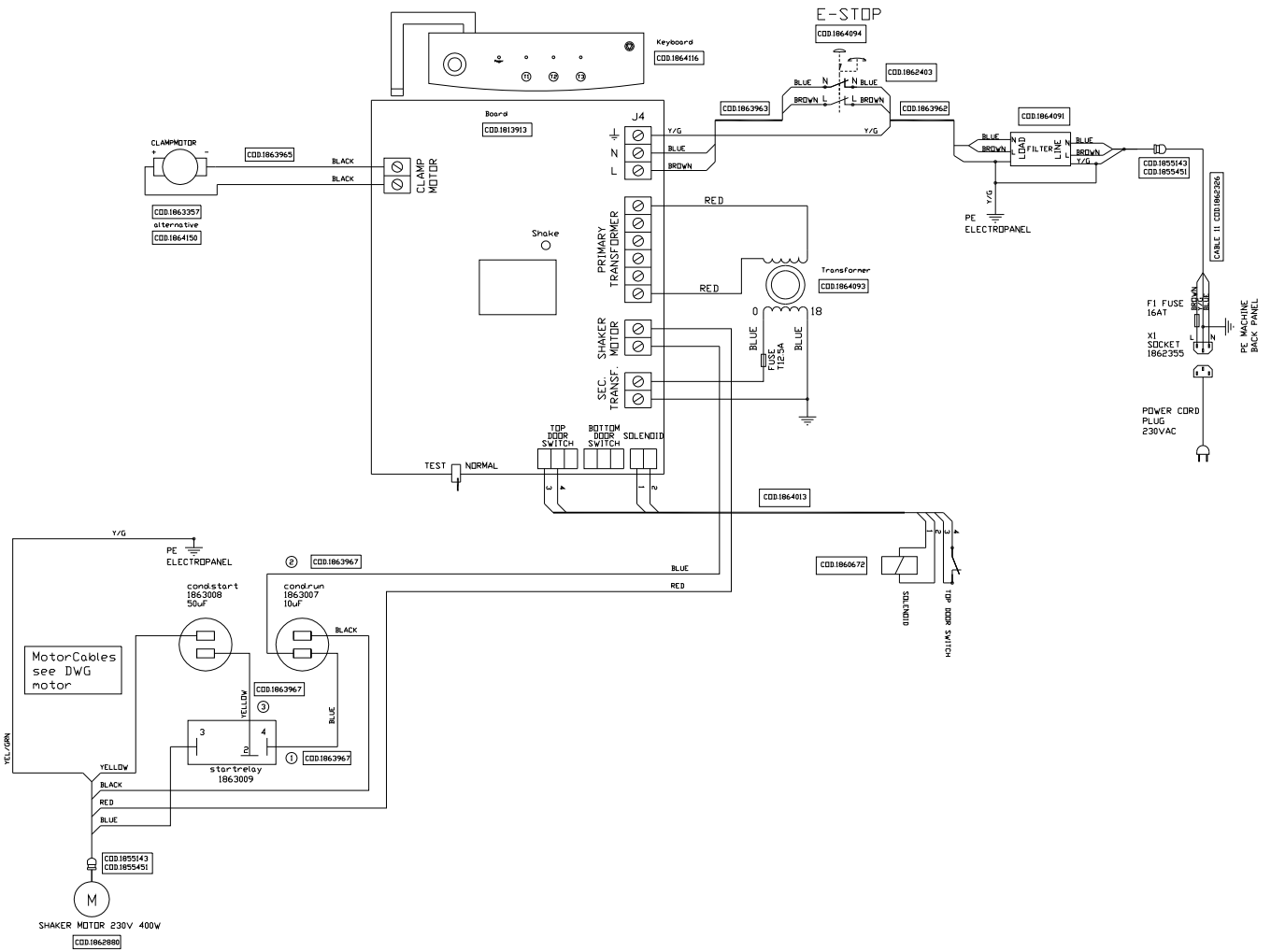

## Contributing to the Protection of the Environment

### Packaging Material

The packaging protects the machine against damage during transport. The packaging material was chosen based on its limited impact on the environment and its inherent possibilities for waste-disposal.

The reuse of packaging material saves raw materials and produces less waste material. Generally speaking, your supplier will take the packaging off your hands.

### Discarding the Machine

Discarded equipment usually still consists of valuable materials. For this reason, do not simply throw your machine out with the oversized refuse, but ask your supplier whether he will take the machine back.

If he will not, then enquire at your local government offices or ask a trader of raw materials what options there are for recycling the material (e.g. scrap processing, electrical components and plastic (see below for additional information)).

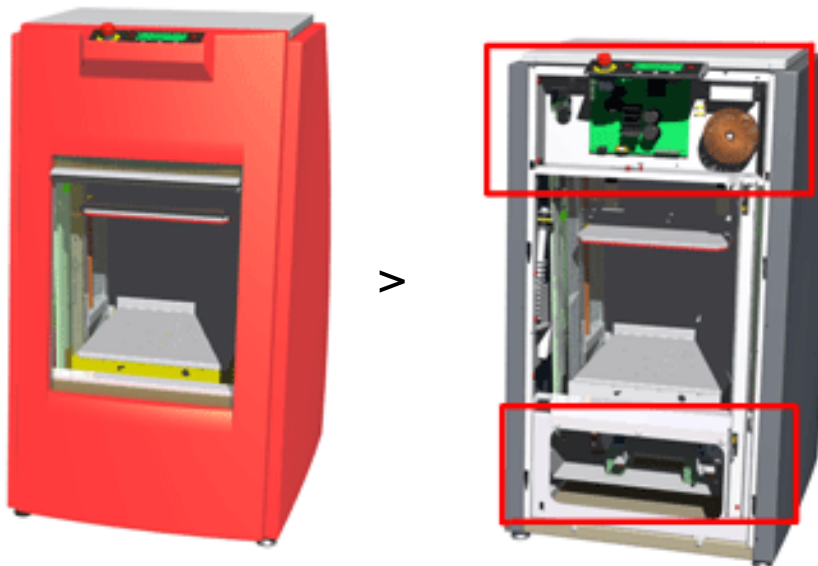

All red-coloured components are made of ABS. These components can be recycled.

Inside the red square pictured above (on the front of the dispenser) are electrical components that can be recycled.

---

© Fast & Fluid Management B.V. 2015  
[www.Fast-Fluid.com](http://www.Fast-Fluid.com)

---